



**Field Service Bulletin  
Service Facility  
Fuel Handling Equipment**

**ENP-380  
Rev. A: July 26, 2017**

## 1. Introduction

Service facilities for natural gas vehicles require specific features to comply with safety and fire prevention regulations. These requirements vary with location (authority having jurisdiction - AHJ), and may be complex.

Natural gas vehicles can be serviced outdoors, but this is often uncomfortable and inconvenient during inclement weather.

The following items and procedures can be used when performing service on a compressed natural gas (CNG) powered vehicle inside an unmodified shop. The items and procedures listed below will enable work on CNG vehicles indoors.

Basically, the vehicle must be depressurized and defueled in order to bring the vehicle indoors. When work is completed, a source of fuel must be supplied to the vehicle so it can be driven, rather than towed, out of the shop, see Figures 1 and 2.

### ***When defueling, remember these important points:***

1. Defueling a CNG fuel system requires careful planning, since the vehicle must be towed, rather than driven to be moved.
2. Methane is a greenhouse gas, so it is best to drive the vehicle to near-empty to minimize the amount of fuel released into the atmosphere.



***Figure 1 Left: Agility Fuel Solutions Pony Tanks are used as a temporary fuel supply; at right is an example of a vent post for defueling.***

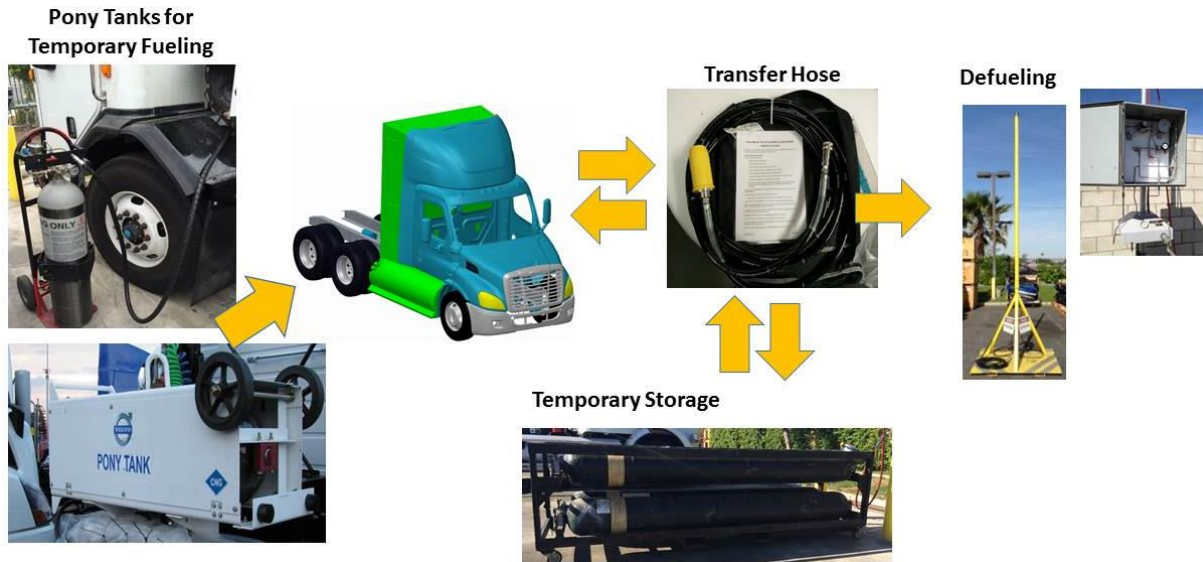

*Figure 2 Upper left: The Agility Fuel Solutions 24403000 Type 2 Pony Tank. Lower left: Pony Tank system number 24400000. Upper center: Defuel hose 20100021. Lower center: Fuel cylinders for safe storage. Upper right: Vent post used to vent residual fuel from vehicle.*

## 2. Affected Service Centers

These suggestions may be applied to any service facility on a temporary or permanent basis.

## 3. Corrective Action

None, this bulletin is for information only.

## 4. Parts, Materials and Tools

- De-fueling/transfer hose: Agility Fuel Solutions Part number 20100021, 35 ft.
- Pony tank\*
- Low pressure hose with appropriate size female swivel JIC fittings to match engine fuel inlet
- Remote fuel module for storing fuel: Call to inquire
- Vent post assembly: Call to inquire

*\* Note: Pony tanks are not approved for use on public roads*

## 5. Procedure – Defuel the System

Fuel must be safely removed from the vehicle before bringing it indoors. A remote CNG storage module can be used to store removed fuel.

Figures 3 and 4 show the location of typical fuel management module (FMM) defueling components on Agility Fuel Solutions equipped vehicles.

These are typical examples, your system may vary slightly.

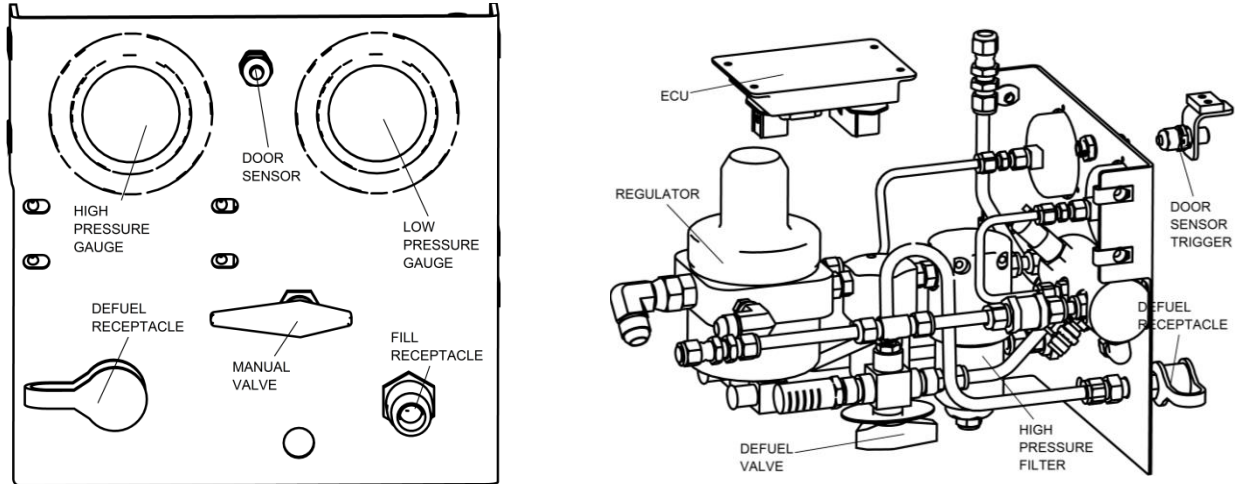

**Figure 3 Left: Cabinet style FMM defuel receptacle, Right: Defuel (3-way) valve.**

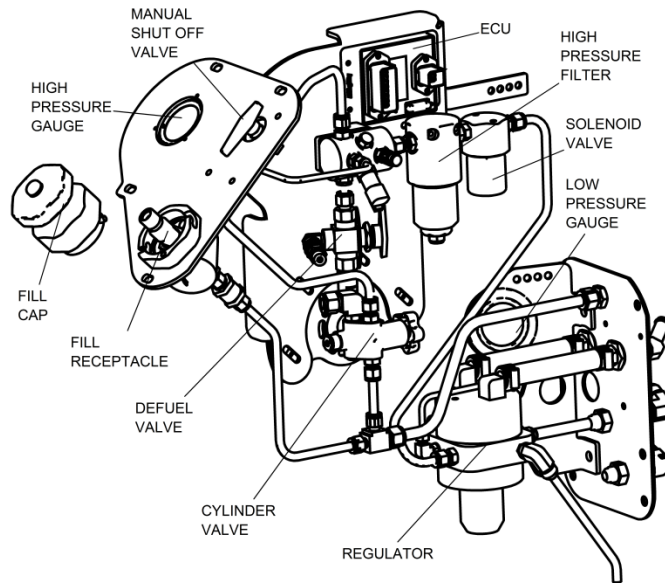

**Figure 4 On side mount systems, the defuel receptacle is attached to the defuel valve.**

1. Connect the de-fuel/transfer hose to the vehicle de-fuel port receptacle at the FMM.
2. Connect the opposite end to the remote CNG module fill port receptacle.
3. Slowly turn the vehicle defuel (3-way ball) valve from “VENT or OFF” to the “DE-FUEL” position.

4. Allow the fuel to transfer into the remote CNG module until pressures have equalized.
5. When complete, vent the system by slowly moving the 3-way valve handle to the “VENT” position. This will depressurize the hose.
6. Remove the de-fuel/transfer hose from the vehicle and CNG module.

**NOTE: This does not completely remove fuel from the vehicle.**

Next, remove the remaining fuel from the vehicle.

**NOTE: Some fueling stations can capture and re-use fuel that is vented to their de-fueling post. Check with your CNG fuel supplier.**

1. Make sure to properly ground the CNG system.
2. Connect the de-fuel/transfer hose to the vehicle de-fuel receptacle at the FMM.
3. Connect the opposite end to the vent post connection.
4. Slowly turn the vehicle defuel (3 way ball) valve handle from “VENT or OFF” to the “DE-FUEL” position, and allow the remaining fuel to vent into the atmosphere.
5. When complete, turn the handle back to the “VENT” position.
6. Remove the de-fuel/transfer hose.
7. The system is now fully defueled.

## 6. Procedure – Supplying Fuel to the Engine

Since there is no fuel onboard the vehicle, fuel must be supplied to the engine using the Pony Tank. Refer to Figure 5. Your installation in the engine bay may vary.



**Figure 5 Connect the hose from the Pony Tank to the low pressure filter inlet at the engine.**

1. Disconnect the CNG system low pressure hose from the engine low pressure filter inlet.
2. Connect the low pressure hose from the Pony Tank to the engine low pressure filter inlet.
3. Open the fuel valve on the Pony Tank and set the pressure to 125 psi.
4. You may now start and run the vehicle.
5. When using the “small” Pony Tank (24403000), have someone “walk” the pony tank alongside the vehicle as it is driven to the shop, as shown in Figure 6.



**Figure 6 Pony Tank 24403000 being used to move a completed refuse vehicle out of the shop and to a staging area.**

- a. The large Pony Tank (24400000) can be temporarily mounted to the vehicle as shown in Figure 7.



**Figure 7 Pony Tank 24400000 can be temporarily mounted on the vehicle to supply fuel to the engine while the vehicle is under construction. Note, Pony Tanks are not approved for use on public roads.**

6. Once the vehicle is in place, close the Pony Tank fuel valve. This isolates the fuel in the fuel cylinder(s).
7. It is now safe to work on the vehicle indoors.

## 7. References

- Agility Fuel Solutions Pony Tank Operation Manual, ENP-005 (for 24400000)
- Agility Fuel Solutions Pony Pallet Operation Manual, ENP-372
- Agility Fuel Solutions Type 2 Pony Tank Operation Manual, ENP-249 (for 24403000)
- Agility Fuel Solutions Truck and Tractor CNG Fuel System Operation Manual, ENP-007
- Agility Fuel Solutions CNG System Users' Manual, ENP-314

## 8. Warranty Information

Does not apply, this is an information-only bulletin.

If you have any questions, contact Agility Fuel Solutions Customer Care: 949-267-7745, toll free: 855-500-2445 or support@agilityfs.com.

## Proprietary Statement

The information provided within this document is proprietary and confidential. All prior versions, including updates and revisions forwarded separately, are proprietary. The information provided by Agility Fuel Solutions to its customers and clients is solely for the use of those customers and clients. No portion of this manual may be reproduced or distributed without express written consent of Agility Fuel Solutions. Agility Fuel Solutions reserves the right to utilize the intellectual property contained within this publication as content for any other publication produced by Agility Fuel Solutions.

## Trademark Notice

Agility® and TUFFSHELL® are registered trademarks of Agility Fuel Solutions. Drop-N-Go™ is a trademark of Agility Fuel Solutions. Trademarks of other manufacturers are the property of their respective companies.

Agility Fuel Solutions | 3335 Susan Street Suite 100 | Costa Mesa, CA 92626 USA

www.agilityfuelsolutions.com

Revision	Description	Author	Approved By	Date
--	Initial Release	W. Yoshida	Y. Coy	4/16/15
A	Revised company name and address	W. Yoshida	M. Meyer	7/26/17